

MotorGuide REPAIR PARTS

Model: **POWERplus**
QS52V

SPECIFICATIONS:

Year of Intro 1998
 Thrust 52LBS
 Volts 12VDC
 Amp Draw 0 to 48 amps
 Mount 09 Transom
 Speeds Variable

QUICK REFERENCE PARTS GUIDE:

Rotary Switch KT150-02
 ON/OFF Switch TT3149-03
 DA Board JF157-03
 MOSFET JF096-07
 Motor Seal Kit 6220
 Slide Pot TT168-06

PARTS ORDERING & TECH ASSISTANCE

MotorGuide Consumer Relations
 Phone 918-831-6989
 Fax 800-982-8093

Send Returned Goods to:
 MotorGuide
 605 Hwy 12 West
 Starkville, MS 39760

Returned Goods must be accompanied with a Returned Goods Authorization. Contact MotorGuide Consumer Relations to obtain RGA.

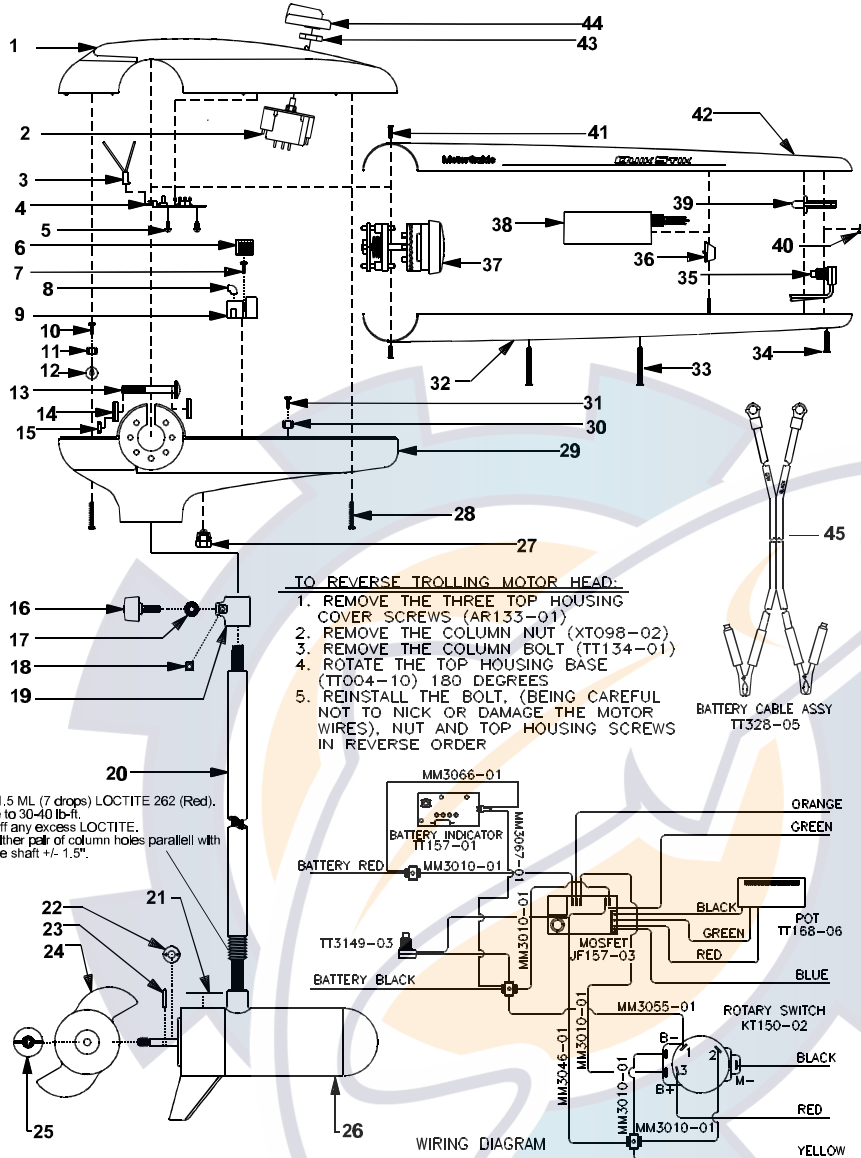

TO REVERSE TROLLING MOTOR HEAD:
 1. REMOVE THE THREE TOP HOUSING COVER SCREWS (AR133-01)
 2. REMOVE THE COLUMN NUT (XT098-02)
 3. REMOVE THE COLUMN BOLT (TT134-01)
 4. ROTATE THE TOP HOUSING BASE (TT004-10) 180 DEGREES
 5. REINSTALL THE BOLT. (BEING CAREFUL NOT TO NICK OR DAMAGE THE MOTOR WIRES). NUT AND TOP HOUSING SCREWS IN REVERSE ORDER

-Apply 1.5 ML (7 drops) LOCTITE 262 (Red).
 -Torque to 30-40 lb-ft.
 -Wipe off any excess LOCTITE.
 -Align either pair of column holes parallel with armature shaft +/- 1.5".

| KEY# | PART# | DESCRIPTION |
|------|----------|-------------------------|
| 1 | TT053-10 | COVER 5 SPD QS GENERIC |
| 2 | KT150-02 | ROTARY SWITCH |
| 3 | WF329-01 | CONNECTOR/JUMPER ASY |
| 4 | TT157-01 | BATTERY LEVEL INDICATOR |
| 5 | AF141-01 | SELF TAPPING SCREW |
| 6 | AP029-01 | AMP CONNECTOR |
| 7 | AF141-01 | SELF TAPPING SCREW |
| 8 | AT080-01 | INSULATING SLEEVE |
| 9 | JF157-03 | 12V DURA AMP BOARD |
| 10 | GR133-01 | 310 X 1/2 SCREW |
| 11 | FT160-03 | TERMINAL (4 PRONG) |
| 12 | TT098-03 | ON SERT PAL NUT |
| 13 | TT134-01 | BOLT |
| 14 | TT171-04 | CURVED WASHER |
| 15 | XT098-02 | NYLON LOCK NUT |
| 16 | AR082-02 | BAR KNOB DEPTH ADJUST |
| 17 | AR171-01 | COLUMN CLAMP WASHER |
| 18 | FR098-01 | COLUMN SUPPORT NUT |
| 19 | AR051-01 | DEPTH ADJUST COLLAR |
| 20 | TT049-04 | COLUMN 30" |
| | FR049-15 | COLUMN 42" |
| 21 | ET060-04 | LOWER UNIT DECAL |
| 22 | AR175-01 | MONOFILAMENT WASHER |
| 23 | BR102-01 | PROP PIN |
| 24 | AF124-10 | 3 BLADE PROP |
| 25 | AR099-01 | PROP NUT |

| KEY# | PART# | DESCRIPTION |
|------|-----------|-----------------------|
| 26 | CF397-05 | LOWER UNIT |
| 27 | GR019-01 | BATTERY CABLE BUSHING |
| 28 | AR133-01 | 8 X 1 3/8 SCREW |
| 29 | TT004-10 | TH BASE GENERIC |
| 30 | FT160-03 | TERMINAL 4 PRONG |
| 31 | GR133-01 | 310 X 1/2 SCREW |
| 32 | TT072-05 | LOWER HANDLE QS BLACK |
| 33 | TT133-03 | #6 X 1" SCREW |
| 34 | TT133-02 | #6 X .75 SCREW |
| 35 | TT3149-03 | ON/OFF SWITCH ASY |
| 36 | TT3001-03 | ACTUATOR ASY |
| 37 | TT372-04 | HANDLE CLUTCH ASY |
| 38 | TT168-06 | POTENTIOMETER |
| 39 | TT001-04 | ACTUATOR ON/OFF |
| 40 | TT177-02 | SWITCH BOOT |
| 41 | TT133-01 | #6 X .437 SCREW |
| 42 | TT072-12 | UPPER HANDLE |
| 43 | AT098-01 | PAL NUT |
| 44 | TT082-06 | ROTARY KNOB |
| 45 | TT328-05 | BATTERY CABLE ASY |

PARTS NOT ILLUSTRATED
 ET056-06 DECAL
 MM5604 OWNERS MANUAL

Model:
QS52V

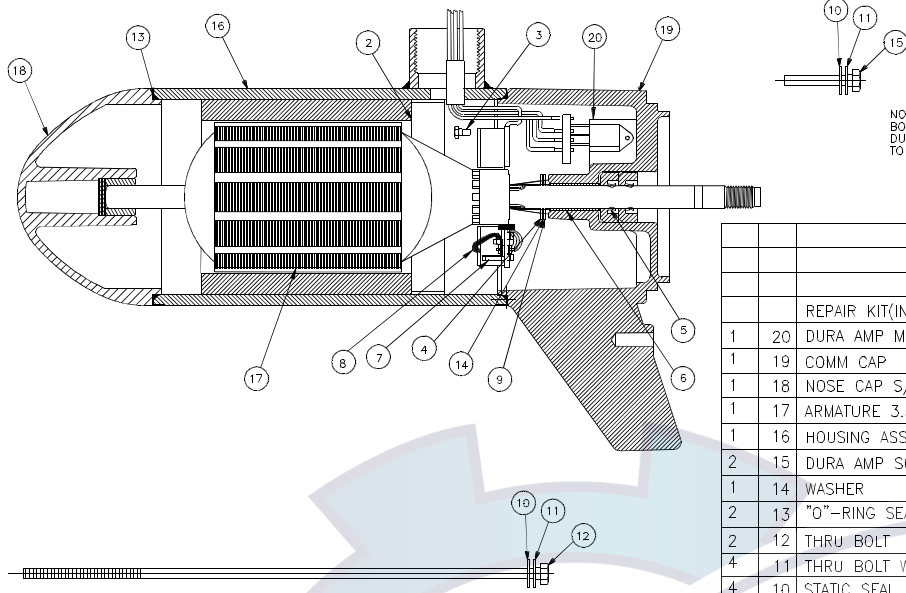

NOTE-TORQUE THRU BOLT, PART No. MR218-02 AND DURA AMP SCREW PART No. MR229-01, TO 35-40 INCH POUNDS

| | | REPAIR KIT(INCLUDES ALL*) | 7317 |
|-----------|----------|-----------------------------------|---------------|
| 1 | 20 | DURA AMP MODULE | JF096-07 |
| 1 | 19 | COMM CAP LESS MOSFET & BRUSH ASSY | JF3205-04DSAW |
| 1 | 18 | NOSE CAP S/A | JF3212-01BSAW |
| 1 | 17 | ARMATURE 3.5" | CF3207-01 |
| 1 | 16 | HOUSING ASS'Y | JF3210-01BSAW |
| 2 | 15 | DURA AMP SCREW | MR229-01 |
| 1 | 14 | WASHER | * MR227-01 |
| 2 | 13 | "O"-RING SEAL | * MR217-01 |
| 2 | 12 | THRU BOLT | MR218-02 |
| 4 | 11 | THRU BOLT WASHER | * MR216-01 |
| 4 | 10 | STATIC SEAL | * MR222-01 |
| 1 | 9 | NYLATRON WASHER | * MR226-01 |
| 1 | 8 | BRUSH ASS'Y-LESS SPRING | JF3201-03 |
| 2 | 7 | BRUSH SPRINGS | * MR214-02 |
| 1 | 6 | BEARING | * MR206-01 |
| 2 | 5 | SHAFT SEAL | * MR223-01 |
| 1 | 4 | "E" RING | MR219-02 |
| 2 | 3 | BRUSH CARD SCREW | MR228-01 |
| 1 | 2 | RETAINER | JF233-01 |
| 1 | 1 | 3.5"-41#-D.A. MOTOR 50" | CF397-05 |
| NO. REQ'D | ITEM NO. | DESCRIPTION | PART NO. |

WIRING

